

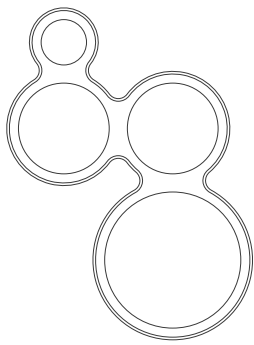

ASSEMBLY INSTRUCTIONS



Lifestyle

Trolley

Tools required: - 2 adjustable spanners
1 phillips head screwdriver

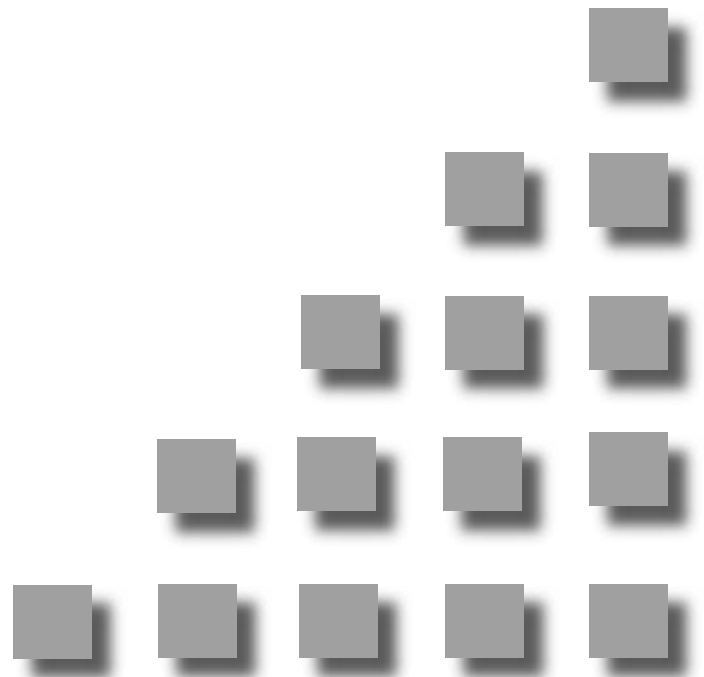

Trolley parts



1 base shelf



4 legs



2 side shelves



2 pairs side shelf brackets



4 castors



4 large washers



4 washers



8 x 10mm bolts



4 short bolts



16 spacers



4 locking nuts



24 long bolts

Extra Cabinet Parts



2 side panels



2 back panels



1 cylinder bracket



1 door catch panel



1 front infill panel



4 or 6 nylon inserts



4 or 6 self tapping screws



24 or 26 short bolts



1 or 2 doors



1 washer



1 small nut

1

Remove protective plastic from all components.

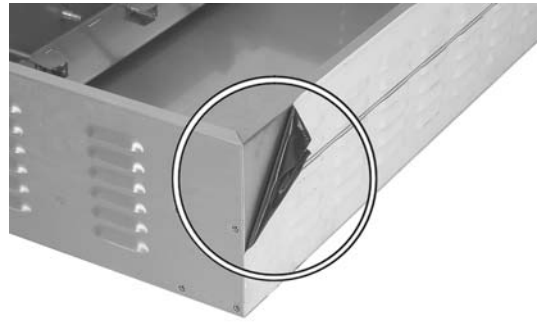

2

YOU WILL NEED
8 x 10 mm bolts

Attach the braces to the side shelves.

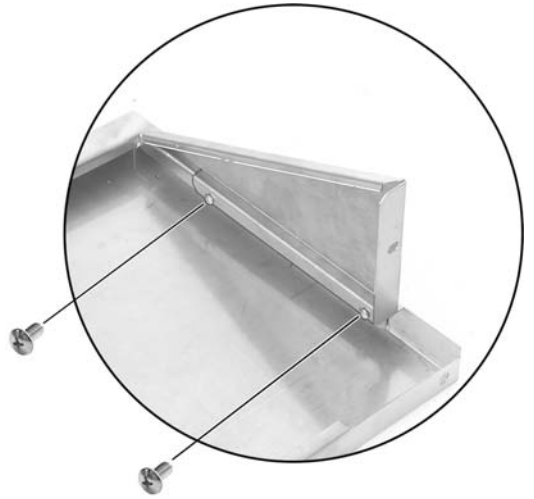
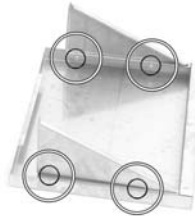

3

YOU WILL NEED
4 short bolts

Put the legs into position. The holes for the castors go at the top. Use one short bolt to secure each leg to the side shelf.

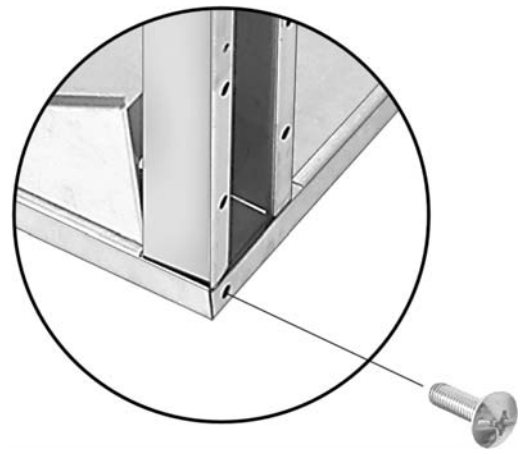

4

YOU WILL NEED
16 long bolts
16 spacers

Turn the barbecue upside down. Attach the legs to the barbecue, with the spacers in between. No need for nuts, the screws go straight into the barbecue

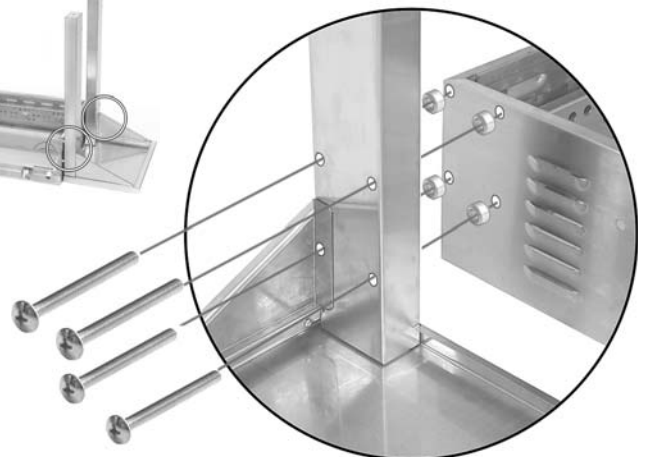

5

YOU WILL NEED

- 4 small washers
- 4 large washers
- 4 locking nuts

Attach the castors. The big washer goes on top, the small washer and nut go underneath.

You will need two spanners to tighten the castors properly.

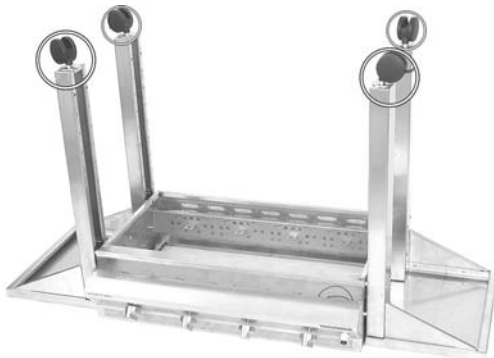

6

YOU WILL NEED

- 8 long bolts

If you have the full cabinet option (with doors and side panels), you should skip this step!

Attach the base shelf with the flat side towards the barbecue. Now tighten up all screws and you are done.

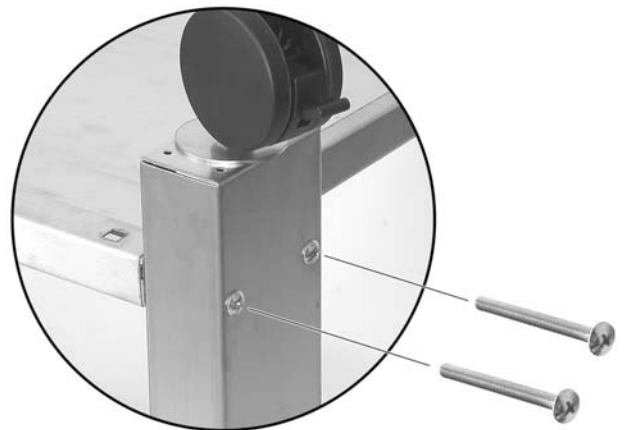

Read on if you have the cabinet option.

7

YOU WILL NEED
2 short bolts

Screw the cylinder bracket to one of the side panels. The top of the bracket passes through the slot in the top of the side panel. You won't need any nuts because the small bolts thread directly into the back of the cylinder bracket.

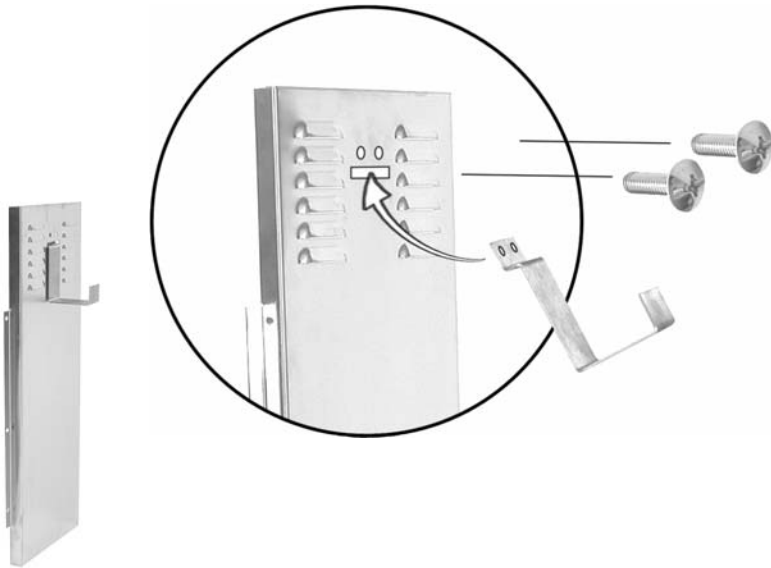

8

YOU WILL NEED
8 short bolts

With the barbecue still upside down, screw the side panels to the legs. The vents go towards the barbecue. The panel with the cylinder bracket goes on the same side as the gas inlet as shown.

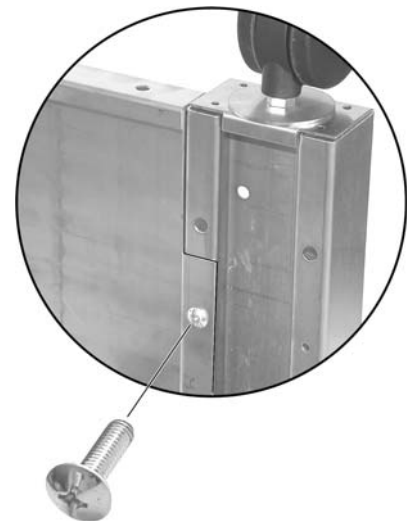

9

YOU WILL NEED
8 long bolts

Turn the barbecue right side up. Screw the base shelf on, but watch the orientation. The flat side goes down, the side with the holes around the edges goes up. Finally, the two holes in the middle go toward the front.

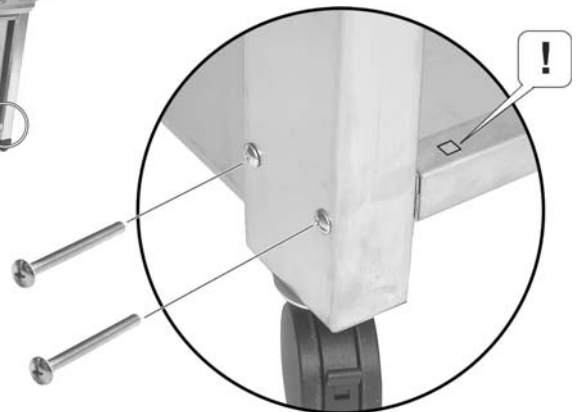

10

YOU WILL NEED

5 short bolts

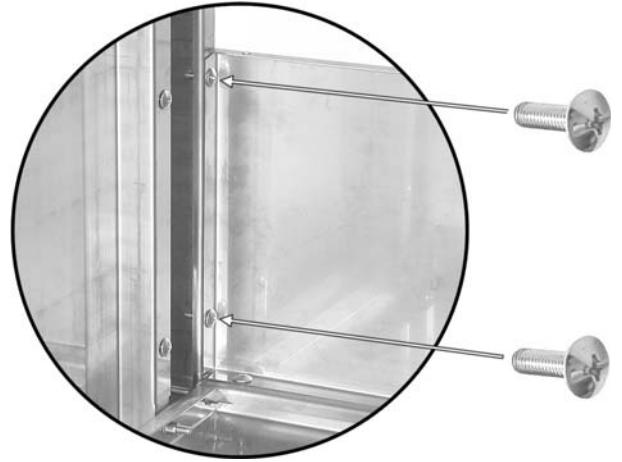

Screw one of the back panels into place.

11

YOU WILL NEED

5 short bolts
1 small washer
1 small nut

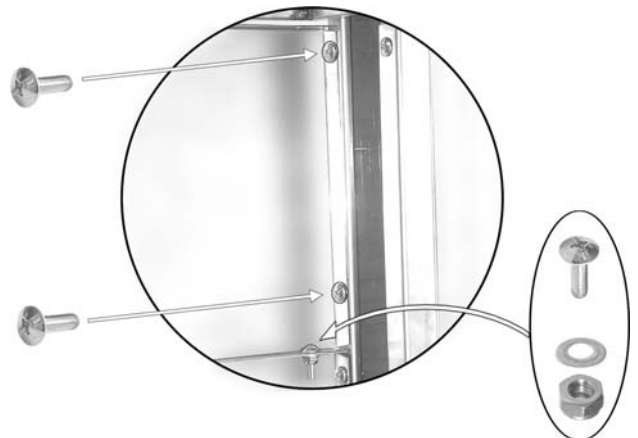

Screw the other back panel into place. Use two screws on each side, and use screws, nuts and washers to screw the two panels together.

12

YOU WILL NEED

4 short bolts

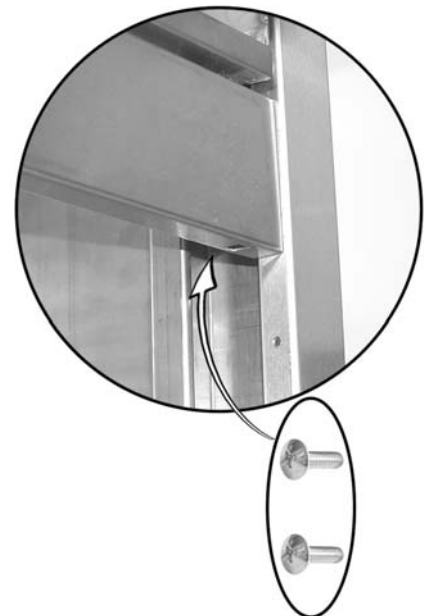

Screw the front "infill" panel into place. You will need to get your screwdriver inside the cabinet to access the screw holes. Make sure the square holes are facing downwards.

13

YOU WILL NEED

4 or 6 nylon inserts

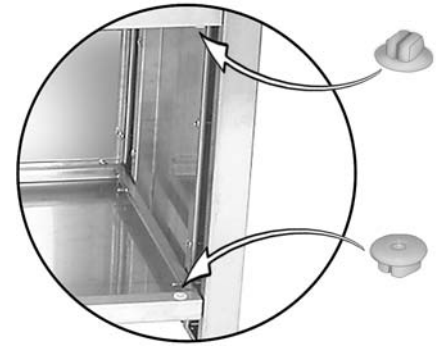

Push the plastic inserts into the square holes. They are used in the next step to receive the screws to hold both the catch plate and the doors. A 2 burner model needs 4 inserts, all others need 6, positioned as in the diagrams. For 2 and 3 burner models, the diagrams show the arrangement of plastic inserts to allow the door to be opened from the left. If you wish, you can allow the door to open from the right by reversing the arrangement of the plastic inserts,

14

YOU WILL NEED

2 short bolts (4 & 5 burner only)

2 or 4 self tapping screws

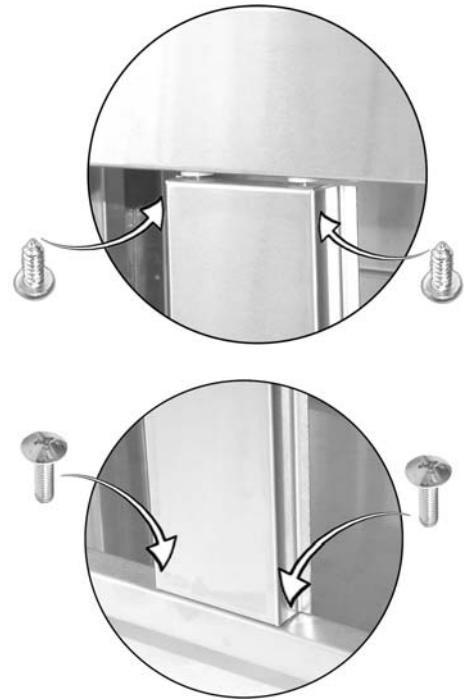

Screw in the door catch panel. For the 2 burner, use two self tapping screws, one at the top and one at the bottom. For the 3 burner, you use two screws at the top and two at the bottom.

For 4 and 5 burners, use two self tapping screws at the top, and two short bolts at the bottom. The two short bolts screw directly into metal nuts that are already attached to the base tray.

15

YOU WILL NEED

2 or 4 self tapping screws

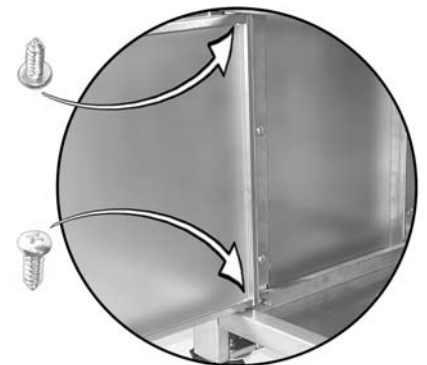

Use self tapping screws to secure the doors into place.

Finally, tighten up all screws and your assembly is complete.



Manufactured by
Australian Barbeque Manufacturers
A division of Custom Group Pty Ltd
51 Norman St
Peakhurst NSW 2210
ph 02-9533-1544
fax 02-9534-4712

CG-LSC-0504